

C&I System

C&I SMART BESS



Application Scenarios

Platform Capacity increase / Industrial & Commercial Companies / Data Center
Campus Storage / Commercial Buildings Large Industrial / Movable Storage



Efficient and Flexible

LiFePO4 battery storage system, two-layer battery management system, fully digital LCD display, Support multi-machine parallel expandable modules.



Application Scenarios

Platform capacity increase, Industrial & Commercial companies, Data centers, Campus storage, Large industrial and commercial buildings, Movable storage.



Safe and Secure

IP54 protection degree outdoor cube, consists of accessories, including air-cooling equipment, lighting, power distribution, fire control, etc.



Efficient Management

Energy management system includes cloud system & local management machine, PCS data collection and other related devices.

Hybrid Series			
Model	30kW/60kWh	60kW/100kWh	60kW/200kWh
Battery Parameter			
Battery Type	LFP(3.2V 100Ah)	LFP(3.2V 280Ah)	LFP(3.2V 314Ah)
Battery System Configuration	1P192S	1P112S	1P208S
Battery System Capacity	61.44kWh	100.35kWh	209kWh
Battery Voltage Range	518.4V-614.4V	302.4V-358.4V	561.2V-665.6V
Battery Cycle Life	6000 Cycles at 0.5C, 80%DOD at 25 °C		
PV Input Parameters			
Maximum Input Power	50kW	100kW	
Maximum Input Voltage	1000V		
MPPT Voltage Range	125V-850V	150V-950V	
Starting Voltage	150V	125V	
Maximum Input Current	40A/40A	8*20A	
Maximum Short-circuit Current	60A/60A	8*30A	
MPPT Quantity	2	4	
Number of Strings Per MPPT Input	2/2/2	2/2/2/2	
Grid-connected Output Parameters			
Rated Output Power	30kW	60kW	
Maximum Apparent Power	30kVA	60kVA	
Rated Output Voltage	400V, 3L/N/PE		
Rated Frequency	50Hz/60Hz		
Maximum Output Current	43.5A	87A	
Off-grid Output Parameters			
Rated Voltage	400V, 3L/N/PE		
Rated Frequency	50Hz /60Hz		
Rated Output Current	43.5A	87A	
Rated Output Power	30kW	60kW	
Maximum Apparent Output Power	33kVA	66kVA	
Off-grid Handover Time	<10ms		
Basic Parameters			
Operating Temperature Range	-25°C~+60°C(>45°C derating)		
Working Altitude	<4000m (> 2000m derating)		
Noise Figure	<45dB	<65dB	
Topology	No transformer isolation		
Cooling Method	Integrated fan		
Relative Humidity Range	0~95%		
DC Connector Type	Push-in terminals		
AC Connector Type	Terminal blocks		
Human-computer Interaction	LCD		

Cloud-based Communication	RS485 (WiFi/4G/GPRS optional)		
BMS Communication Mode	CAN		
Meter Communication Mode	RS485		
Self-consumption at Night	<10W		
Maximum Efficiency	98.1%	98.5%	
European Efficiency	97.5%		
Protection	AC overcurrent protection, Ground fault protection Grid monitoring and protection, Residual current detection protection		
System Parameter			
System Efficiency	>88%		
Size (W*D*H)	1694*576*880mm	1070*1141*2250mm	1465*1141*2220mm
Weight	0.65T	1.36T	2.07T
Operation Ambient Temperature	-20°C~55°C		
Operation Humidity Range	0 ~ 95%		
Work Altitude	<2000m	<3000m	
Protection Degree	IP54		
Anti-Corrosion Degree	C4		
Cooling Method	Air Cooling		
Fire Suppression System	Aerosol		

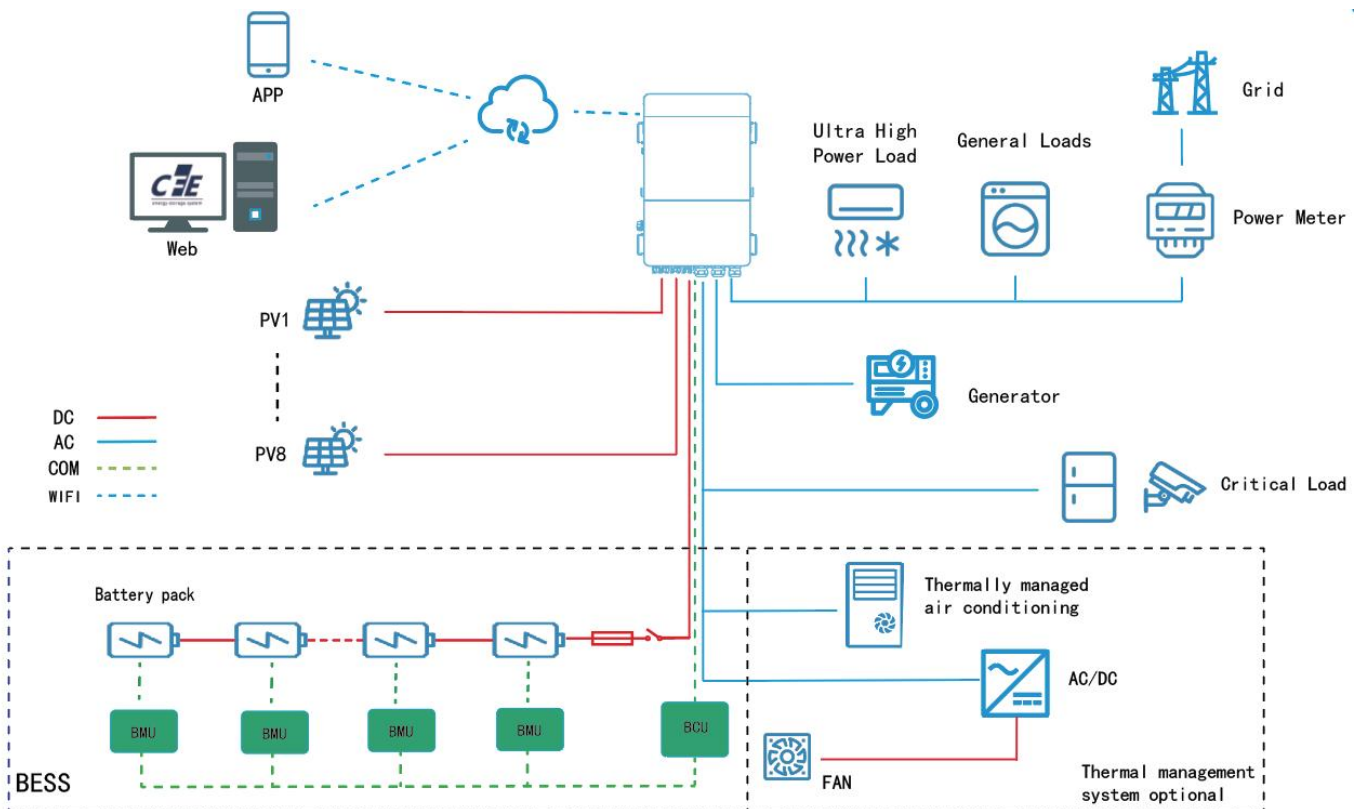

On/Off Grid Series				
Model	100kW/200kWh	125kW/241kWh	100kW/233kWh	125kW/250kWh
Battery Parameter				
Battery Type	LFP(3.2V 280Ah)	LFP(3.2V 314Ah)	LFP(3.2V 280Ah)	LFP(3.2V 314Ah)
Battery System Configuration	1P240S		1P260S	
Battery System Capacity	215.04kWh	241.15kWh	232.96kWh	261.24kWh
Battery Voltage Range	672V-876V	648V-864V	728V-949V	720V-936V
Battery Cycle Life	6000 Cycles at 0.5C, 80%DOD at 25 °C			
DC Side Parameters				
Number of Ways	1			
DC Voltage Range	672V-876V	648V-864V	728V-949V	720V-936V
DC Maximum Current	177A	198A	177A	198A
Rated DC Power	100kW	125kW	100kW	125kW
Voltage Regulation Accuracy	≤±2%			
Current Stabilization Accuracy	≤±5%			
Voltage-Limiting Feature	Yes			
Current Limiting Characteristics	Yes			
AC Grid-Connected Parameters				
The Rated Output	100kW	125kW	100kW	125kW
Overload Capacity	1.1 times long-term, 1.2 times 1min			
Rated Voltage	AC 400V			
Rated Output Current	145A	180A	145A	180A
AC Access Mode	Three-phase four-wire			
Isolation Method	Non-isolated			
Grid Voltage Range	380V(-20%~+15%)			
Grid Frequency Range	50Hz/60Hz±2.5Hz			
Total Harmonic Distortion	≤3% (Full Load)			
Power Factor	-0.99~+0.99			
DC Component	≤0.5%			
Charge/Discharge Conversion Time	<100ms			
AC Off-Grid Parameters				
AC Off-grid Voltage	AC400V			
AC Voltage Range	AC400V±3%			
AC Off-grid Frequency	50Hz/60Hz			
Off-grid Output THDU	≤3% (linear load)			
Unbalanced Load Capacity	100%			
Basic Parameters				
Maximum Conversion Efficiency	≥98%			
Allowable Ambient Temperature	-20°C~60°C			
Permissible Relative Humidity	≤95%			

Noise	≤75dB			
Altitude	Larger than 2000 meters need to be derated			
BMS Communication Interface	CAN			
EMS Communication Interface	Ethernet port			
Communication Between Modules	Optical fiber			
System Parameter				
System Efficiency	>88%			
Size (W*D*H)	1600*1250*2375mm		1400*1300*2375mm	
Weight	2.9T	3.0T	2.8T	2.9T
Ambient Temperature	-20°C~55°C			
Environment Humidity	0 ~ 95%			
Work Altitude	<3000m			
Protection Level	IP54			
Corrosion Protection Level	C4			
Cooling Method	Air Cooling		Liquid cooling	
Fire Fighting System	Aerosol			

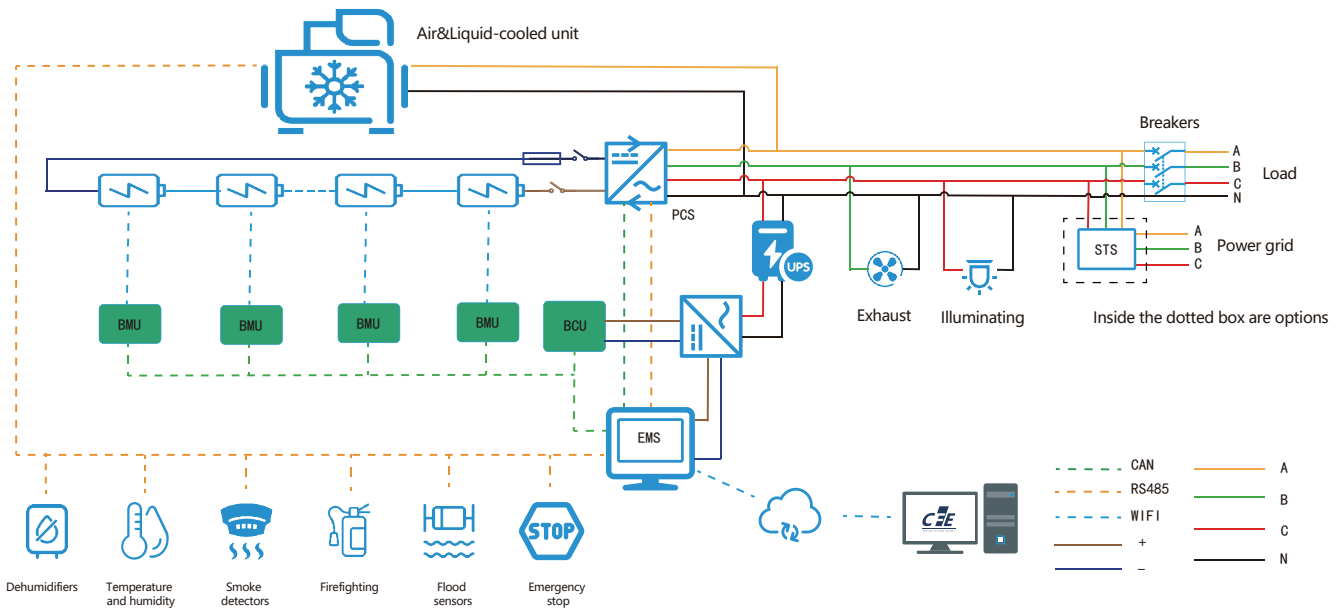

On Grid Series		
Model	186kW/372kWh	200kW/400kWh
DC Side Parameters		
Cell Type	LFP(3.2V 280Ah)	LFP(3.2V 314Ah)
Battery PACK	1P52S/46.592kWh	1P52S/52.249kWh
Battery System	1P416S	
Battery Voltage Range	1123.2V~1497.6V	
Battery System Capacity	372kWh	418kWh
AC Parameters (Grid Connection)		
Rated Power	186kW	210kW
Maximum Output Power	205kW	230kW
Rated Grid Voltage	690V	
Rated Grid Frequency	50Hz	
Factor	-1~+1	
Alternating Current Harmonics (THDi)	<3% (at rated power)	
Access Mode	3P3W	
Full Power Charge/Discharge Transition Time	<30ms	
DC Component	<0.5%In	
Overload Capacity	1.1 times long-term, 1.2 times 1min	
System Parameters		
System Efficiency	≥88%	
Size (W*D*H)	1370*1340*2470mm	
Weight	4.5T	4.6T
Charge-discharge Rate	≤0.5P	
Number of Cycles	>6000 times @25+2°C 0.5P; EOL 80%	
Relative Humidity is Allowed	0~95% (no condensation)	
Ingress Protection	IP55	
Cooling Method	Liquid Cooled (Battery) + Air Cooled (PCS)	
Communication Interfaces	RS485/LAN	
Communication Protocols	MODBUS-TCP	
Fire Protection System	PACK grade perfluorohexanone fire protection + active warning	
Maximum Operating Altitude	4000m (> 2000m need to be derated)	
Cooling Method	Liquid cooling	
Fire Fighting System	Aerosol	

C&I BESS All-in-One Standard Parameter Quick Reference

Model of the all-in-one	30kW/60kWh	60kW/100kWh	60kW/200kWh	100kW/200kWh	125kW/241kWh	100kW/233kWh	125kW/250kWh	186kW/372kWh	200kW/400kWh	
Rated Power (kW)	30	60	60	100	125	100	125	186	215	
Rated Capacity (kWh)	60	100	208	215	240	230	261	372	418	
AC Output Voltage (V)	400							690		
DC Battery Voltage (V)	614.4	358.4	665.6	864.0		936.0		1497.6		
PCS Type	Hybrid			PCS						
Grid Connection	On-grid & Off-grid							On-grid		
STS	Including							Excluding		
Maximum Parallel Quantity	4							20		
Cell Type (Ah)	100	280	314	280	314	280	314	280	314	
Cooling Method	N/A	Air-cooling				Liquid-cooling				
Safety	FK5112									
System Series & Parallel Connection	S/PACK	32	16	16	16	16	52	52	52	52
	S/RACK	6	7	13	15	15	5	5	8	8
	P/BESS	1	1	1	1	1	1	1	1	1
Actual capacity (kWh)	61.44	100.35	209.00	215.04	241.15	232.96	261.25	372.74	417.99	
System Dimensions (mm)	W	1,694	1,070	1,465	1,600	1,600	1,400	1,400	1,370	1,370
	D	576	1,141	1,141	1,250	1,250	1,300	1,300	1,340	1,340
	H	880	2,250	2,220	2,375	2,375	2,375	2,375	2,470	2,470
Gross Weight (T)	0.65	1.36	2.07	2.90	3.00	2.80	2.90	4.50	4.60	

Note: This table is for a quick comparison of product parameters. For detailed technical data, please refer to the technical manual.



CF Energy Co., Ltd.

CFE has offices & warehouses in the following regions where you can get in touch with us:-

Europe: Vienna (Austria) , Budapest (Hungary) Africa: Johannesburg (South Africa)

Asia: Xi'an, Shenzhen, Tianjin, Hong Kong (China) , and Yangon (Myanmar)

Tel: (+86) 029 38367888 Web: www.cfess.cn E-mail: cfenergy@cfess.cn